



Backer Rod Mfg. Inc.

www.backerrod.com
Customer Service (800) 595 2950



UL System No. FF-S-0020

November 18, 2008

Assembly Rating – 4 Hr

Joint Width – 2 In. Maximum

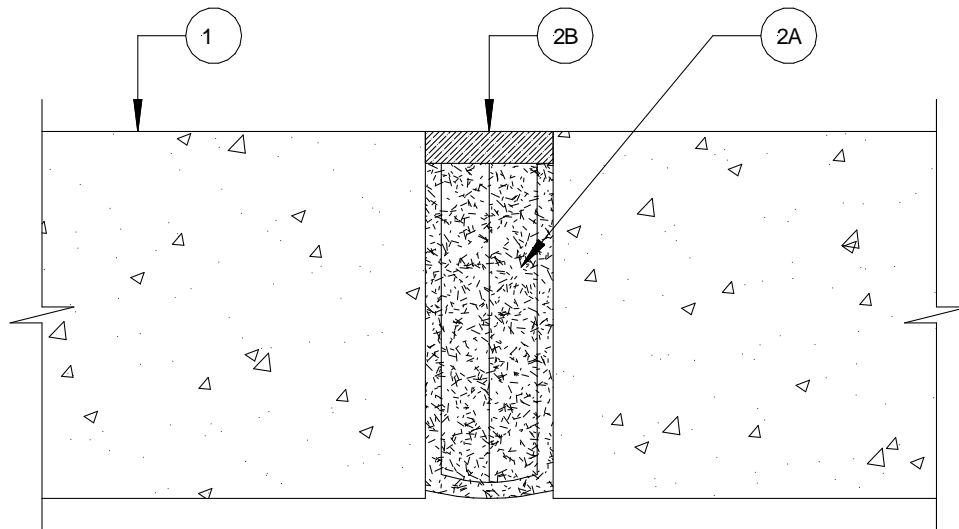

1. **Floor Assembly** – Min 5-3/4 in. (146 mm) thick reinforced lightweight or normal weight (100 – 150 pcf or 1600-2400 kg/m³) structural concrete.
2. **Joint System** – Max width of the joint is 2 in. (51 mm). The joint system shall consist of the following:
 - A. **Forming Material*** - Max 12 in. (305 mm) width of forming material shall be folded in half and packed into joint opening as a permanent form. Forming material to be recessed from top surface of the floor to accommodate the required thickness of fill material.
BACKER ROD MFG. INC. – ULTRA BLOCK®
 - B. **Fill, Void or Cavity Material*** - Min 1/2 in. (13 mm) thickness of fill material applied within the joint, flush with top surface of the floor.
MOMENTIVE PERFORMANCE MATERIALS – PENSIL 300 or PENSIL 300 S/L SEALANTS
SPECIFIED TECHNOLOGIES INC – PENSIL 300, PENSIL 300 S/L, SPECSEAL SERIES SIL300 or SPECSEAL SERIES SIL300SL SEALANTS

*Bearing the UL Classification Mark