



# Backer Rod Mfg. Inc.

[www.backerrod.com](http://www.backerrod.com)  
Customer Service (800) 595 2950



## UL System No. FF-S-1007

August 11, 1995

Assembly Rating – 3 Hr

Joint Width – 3 In. Maximum

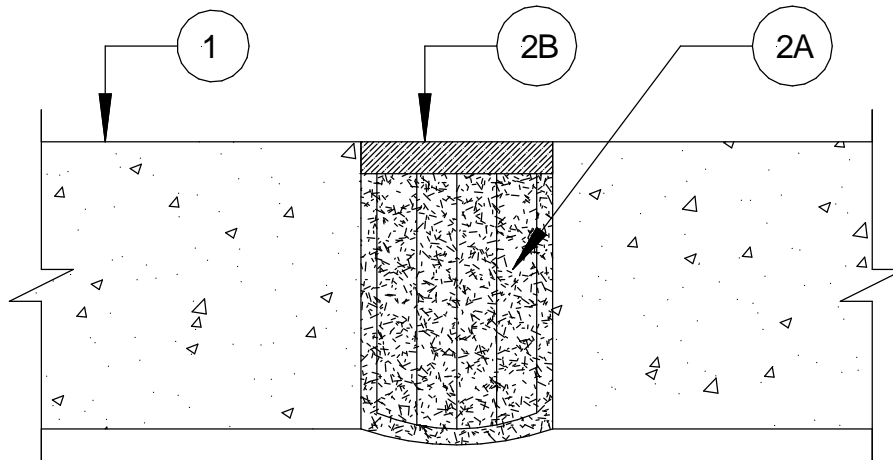

1. **Floor Assembly** – Min 4 ½ in. thick reinforced lightweight or normal weight (100 – 150 pcf) structural concrete.
2. **Joint System** – Max width of the joint is 3 in. The joint system shall consist of the following:
  - A. **Forming Material\*** - A nom 11 in. width of forming material shall be folded in half and firmly packed into joint opening as a permanent form. Forming material to be recessed from top surface of floor as required to accommodate the required thickness of fill material. See manufacturer's installation instructions for size and configuration of forming material.  
**BACKER ROD MFG. INC. – ULTRA BLOCK®**
  - B. **Fill, Void or Cavity Material\*** - Prior to the installation of the caulk material into the joint, interior surfaces of the concrete slab shall be treated with Pecora Primer P-75 in accordance with the installation instructions accompanying the primer. Min ½ in. thickness of fill material applied within the joint, flush with top surface of floor.  
**PECORA CORP – DYNATROL II**

\*Bearing the UL Classification Mark