



Backer Rod Mfg. Inc.

www.backerrod.com
Customer Service (800) 595 2950



UL System No. WW-S-0023

November 19, 2008

Assembly Rating – 4 Hr

Joint Width – 2 In. Maximum

(Limited to Fire Exposure on Interior Surface Only)

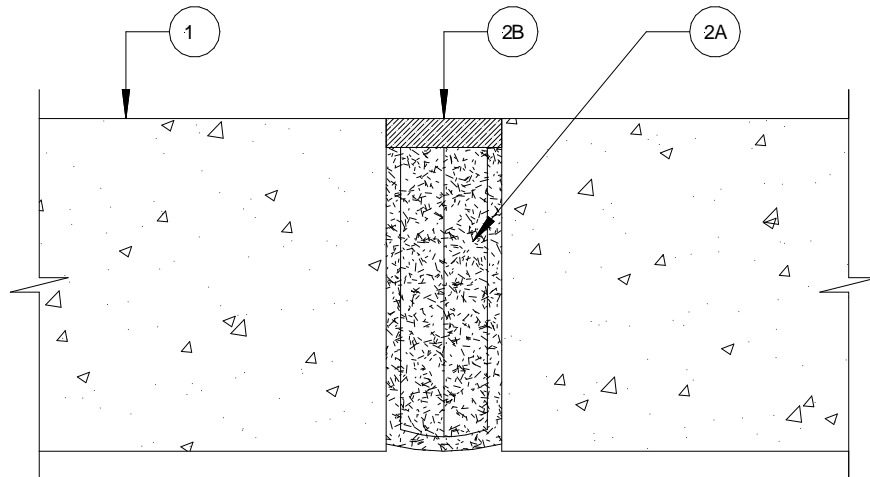

1. **Wall Assembly** – Min 5-3/4 in. (146 mm) thick reinforced lightweight or normal weight (100 – 150 pcf or 1600-2400 kg/m³) structural concrete. Wall may also be constructed of any UL Classified **Concrete Blocks***.

See **Concrete Blocks (CATZ)** category in the Fire Resistance Directory for names of manufacturers.

2. **Joint System** – Max width of the joint is 2 in. (51 mm) The joint system shall consist of the following:

- A. **Forming Material*** - Max 12 in. (305 mm) width of forming material shall be folded in half and packed into opening as a permanent form. Forming material to be recessed from exterior surface of wall as required to accommodate the required thickness of fill material.

BACKER ROD MFG. INC. – ULTRA BLOCK®

- B. **Fill, Void or Cavity Material*** - Min ½ in. (13 mm) thickness of fill material applied within the joint, flush with exterior surface of wall.

MOMENTIVE PERFORMANCE MATERIALS – PENSIL 300

SPECIFIED TECHNOLOGIES INC – PENSIL 300 or SPECSEAL SERIES SIL300 SEALANTS

* Bearing the UL Classification Mark