



Backer Rod Mfg. Inc.

www.backerrod.com

Customer Service (800) 595 2950



UL System No. WW-S-1016

April 15, 2009

Assembly Rating – 4 Hr

Joint Width – 4 In. Maximum

(Configuration No. 1 Limited to Fire Exposure on Interior Face Only)

CONFIGURATION NO. 1

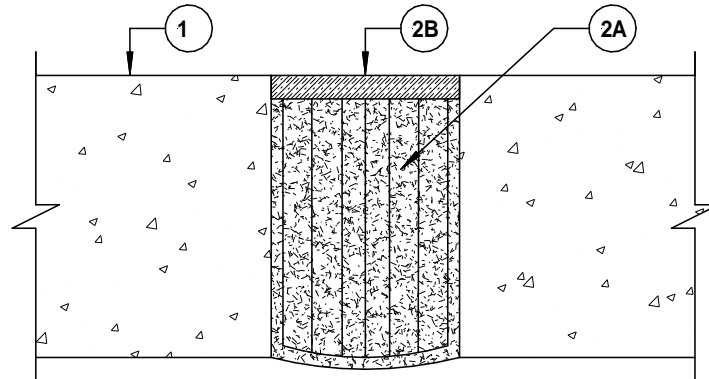

CONFIGURATION NO. 2

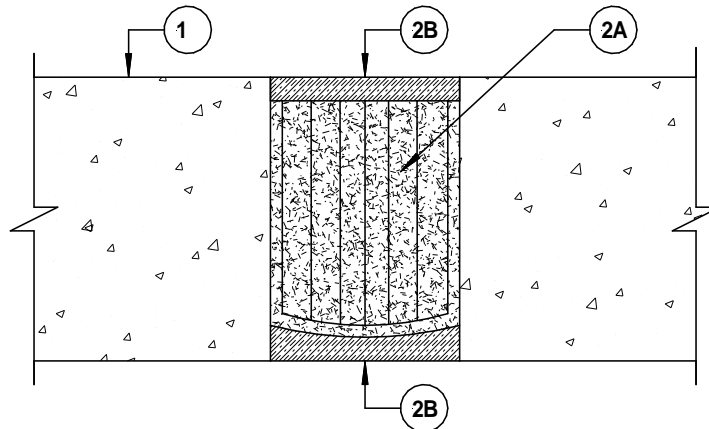

1. **Wall Assembly** – Min 6 in. thick reinforced lightweight or normal weight (100 – 150 pcf) structural concrete. Wall may also be constructed of any UL Classified **Concrete Blocks***. See **Concrete Blocks (CATZ)** category in the Fire Resistance Directory for names of Manufacturers.
2. **Joint System** – Max width of the joint is 4 in. The joint system shall consist of the following:
 - A. **Forming Material*** - In Configuration No. 1, a nom 16 in. width of forming material shall be folded in half and firmly packed into opening as a permanent form. Forming material to be recessed from exterior face of wall as required to accommodate the required thickness of fill material. See manufacturer's installation instructions for size and configuration of forming material. In Configuration No. 2, a nom 16 in. width of forming material shall be folded in half and firmly packed into opening as a permanent form. Forming material to be recessed from each surface of wall as required to accommodate the required thickness of fill material. See manufacturer's installation instructions for size and configuration of forming material.

BACKER ROD MFG. INC. – ULTRA BLOCK®
 - B. **Fill, Void or Cavity Material*** - In Configuration No. 1, min ½ in. thickness of fill material applied within the joint, flush with exterior face of wall. In Configuration No. 2, min ½ in. thickness of fill material applied within the joint, flush with each surface of wall.

BASF CONSTRUCTION CHEMICAL LLC – SONOLASTIC NP 1 or NP2

* Bearing the UL Classification Mark